

ATTACHMENT METHODS

POST SIZE AND DRILLED HOLE SIZE

A	B	HOLE SIZE	EMBEDMENT
100	100	N/A	1.067m
100	150	38	1.372m

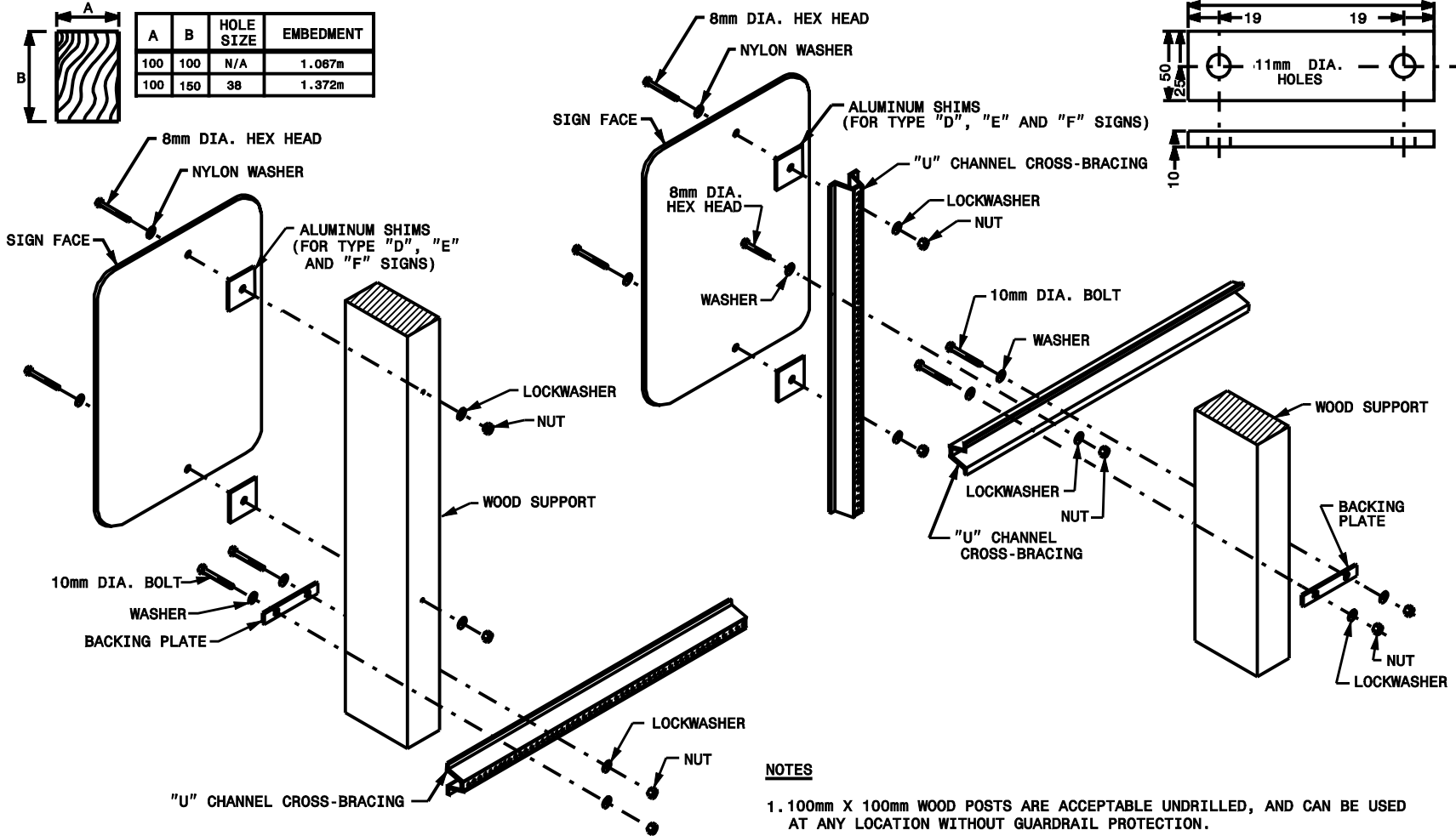

NOTES

1. 100mm X 100mm WOOD POSTS ARE ACCEPTABLE UNDRILLED, AND CAN BE USED AT ANY LOCATION WITHOUT GUARDRAIL PROTECTION.
2. 100mm X 150mm WOOD POSTS MUST BE USED WITH GUARDRAIL PROTECTION OR DRILLED TO MAKE THEM BREAKAWAY. (DRILLED WITH 38mm HOLES, PERPENDICULAR TO THE DIRECTION OF TRAVEL, LOCATED 100mm AND 450mm ABOVE THE GROUND)
3. USE "U" CHANNEL POSTS FOR CROSS-BRACING SIGNS SUPPORTED BY DUAL WOOD POSTS.