

APPENDIX C

Typical Comprehensive Transportation Plan Cross-Sections

APPENDIX C: TYPICAL HIGHWAY CROSS SECTIONS

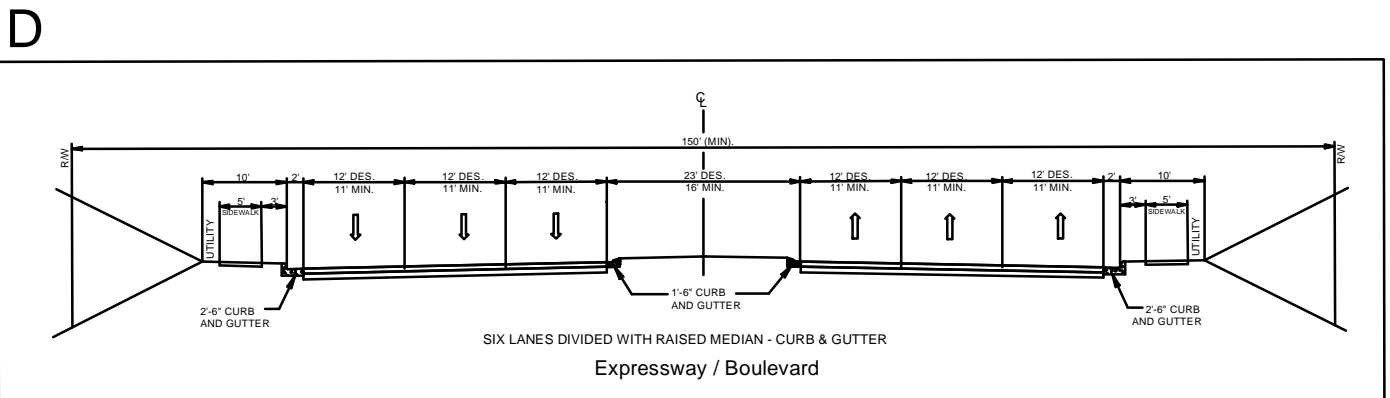
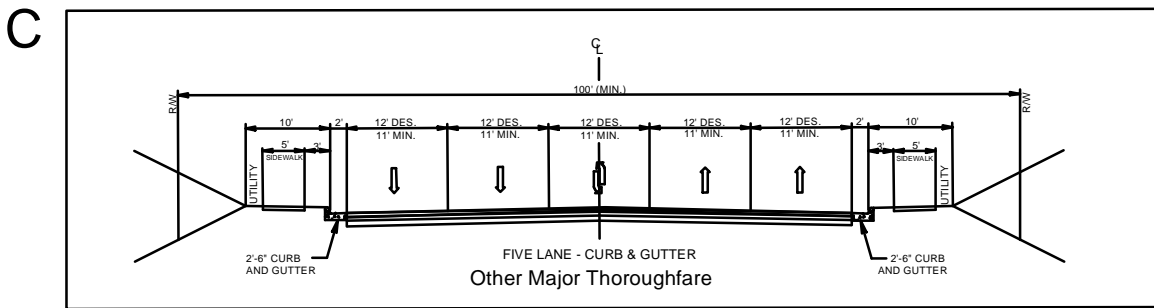
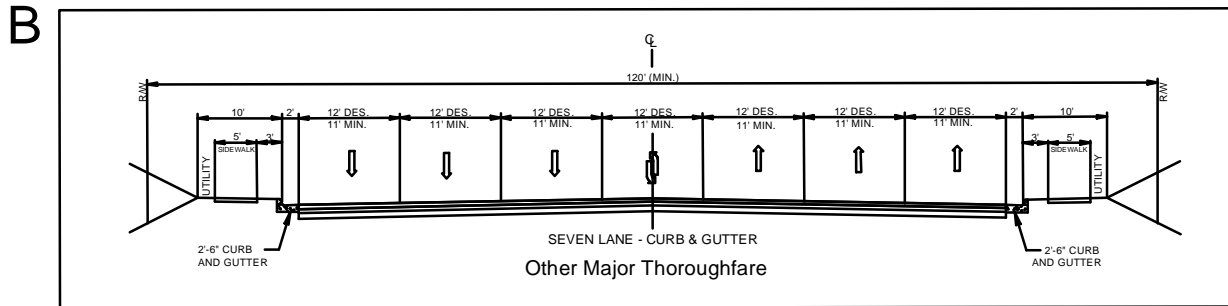
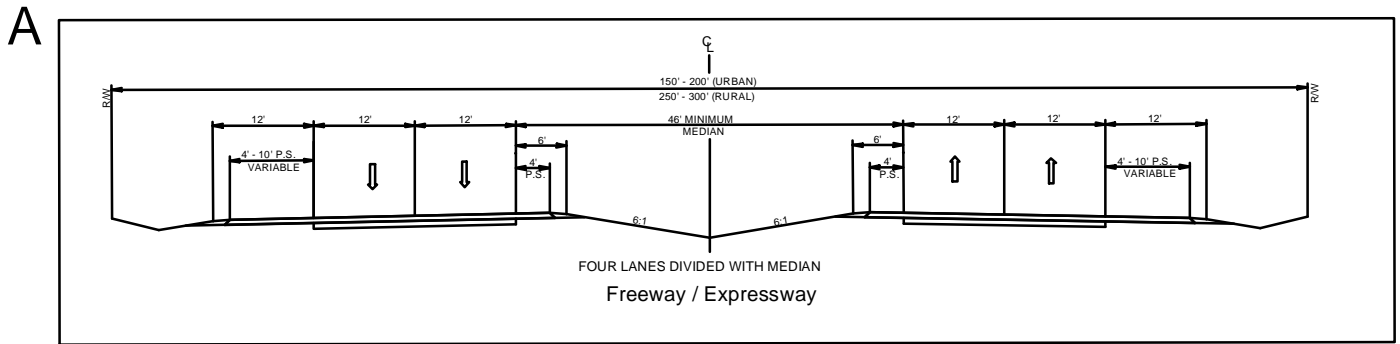

APPENDIX C: TYPICAL HIGHWAY CROSS SECTIONS

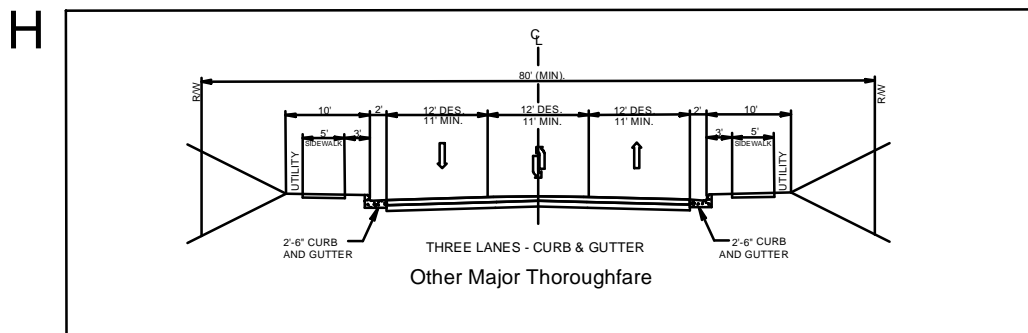
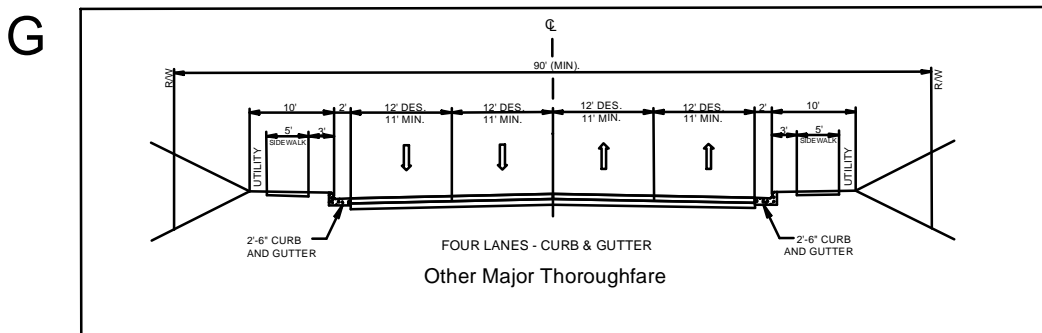
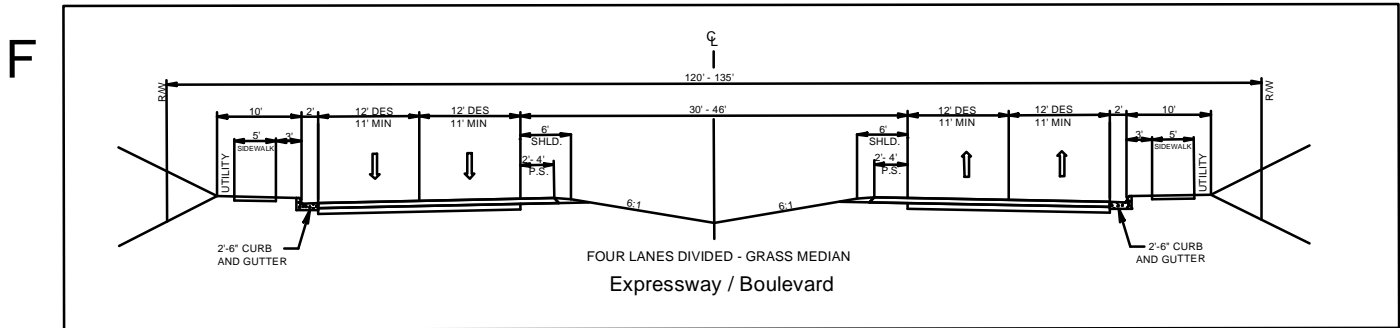
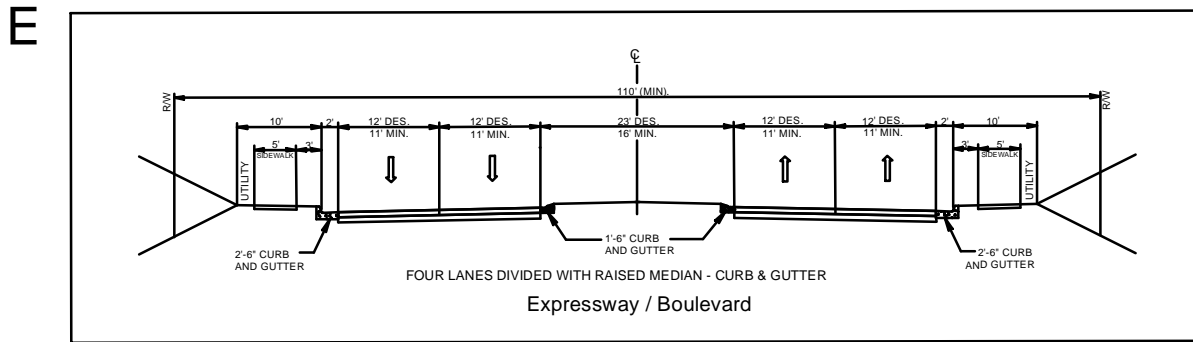

APPENDIX C: TYPICAL HIGHWAY CROSS SECTIONS

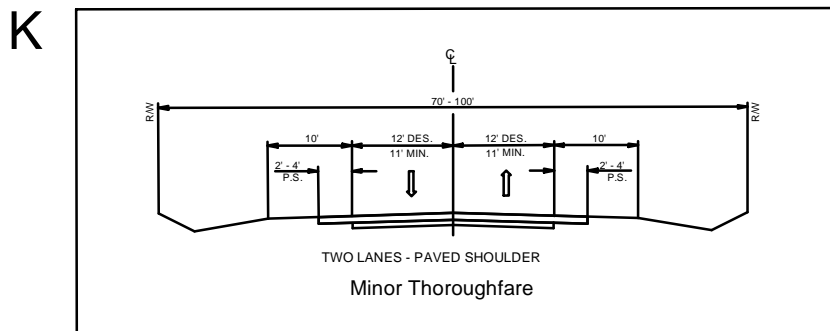
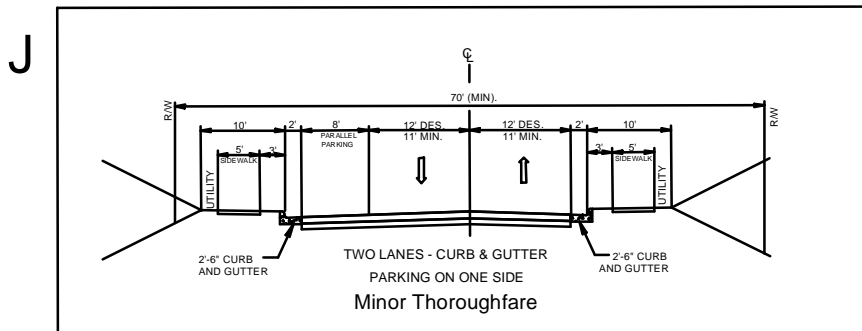
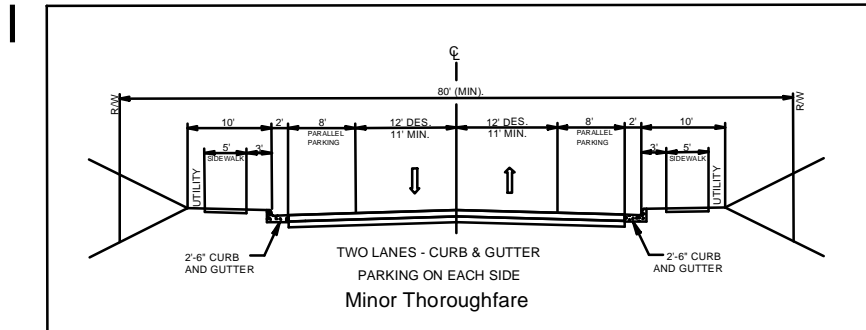

APPENDIX C:

TYPICAL HIGHWAY CROSS SECTIONS

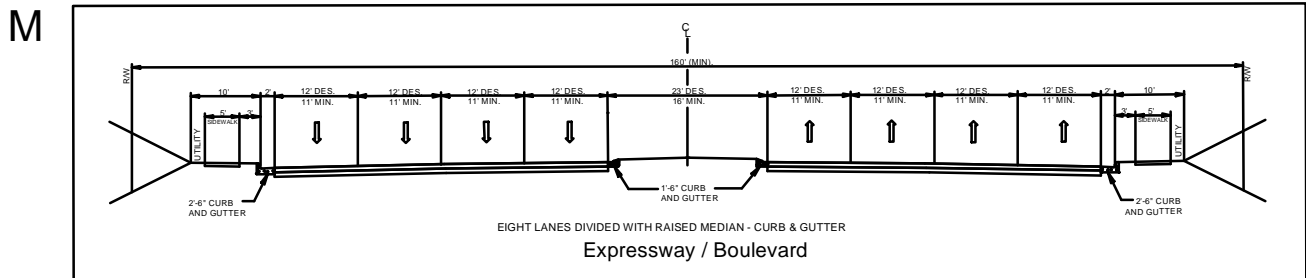
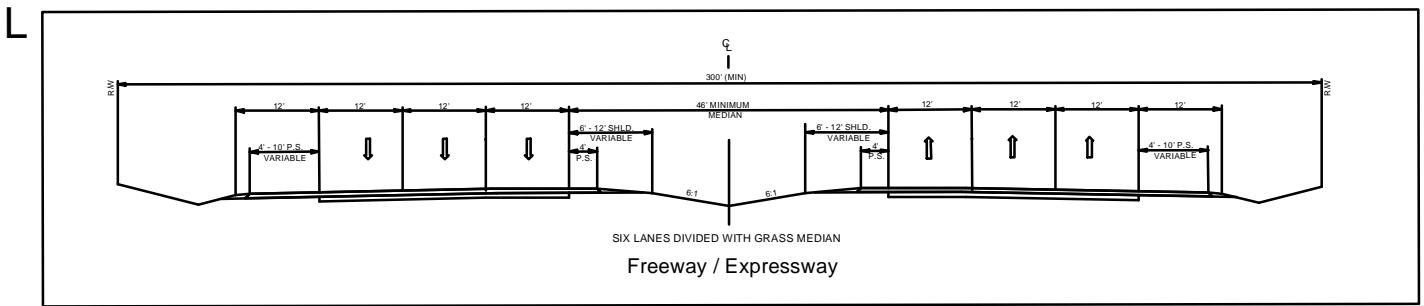

Typical Bicycle Cross Sections

WIDE CURB LANES

B-1 4-LANE MEDIAN DIVIDED TYPICAL SECTION

With Wide Outside Lanes

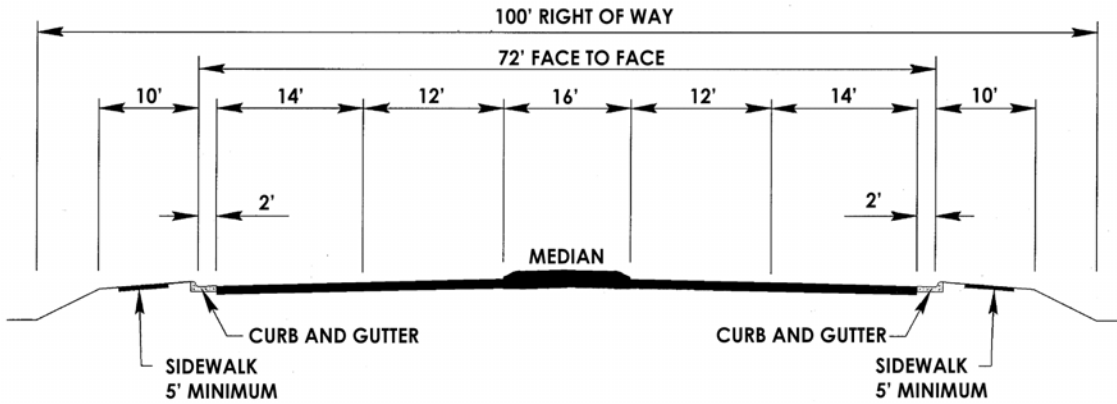

B-2 5-LANE TYPICAL SECTION

With Wide Outside Lanes

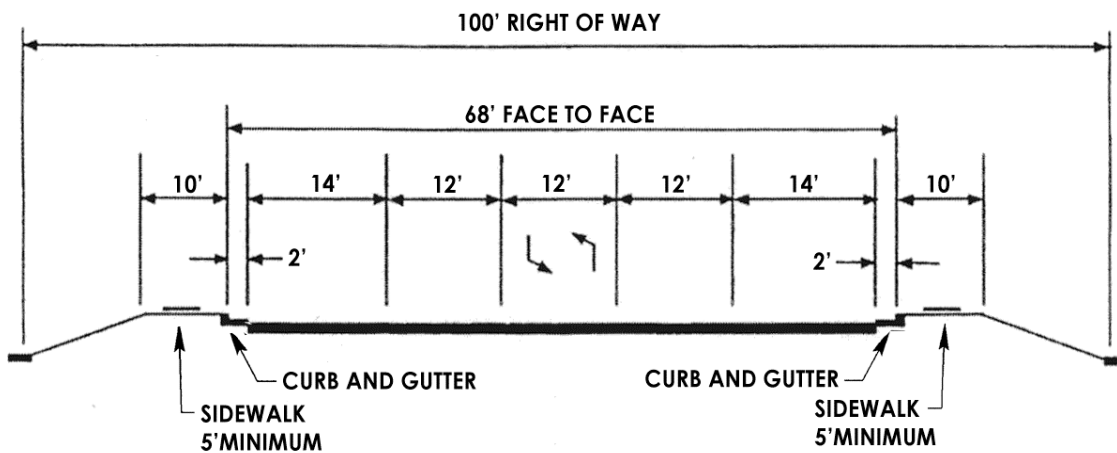

Typical Bicycle Cross Sections

B-3 BICYCLE LANES ON COLLECTOR STREETS

Existing Roadway

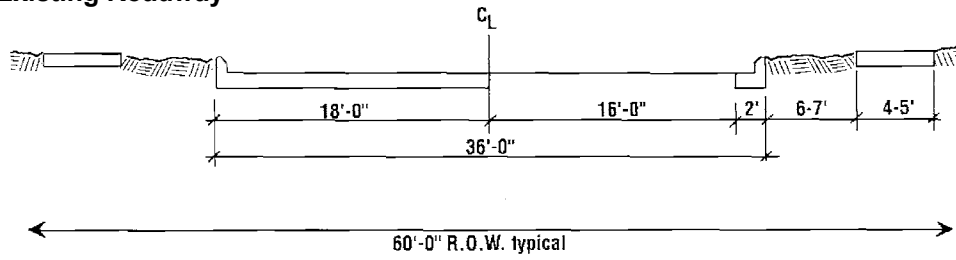

Restriping to Accommodate Bicycle Lanes (Does Not Allow On-Street Parking)

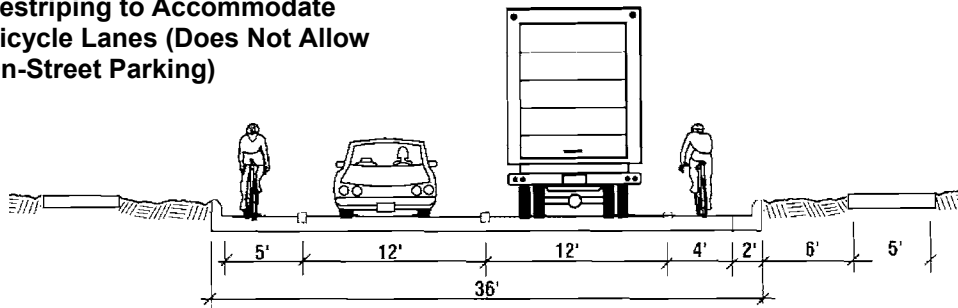

Typical Bicycle Cross Sections

B-4 WIDE PAVED SHOULDERS

Existing Roadway

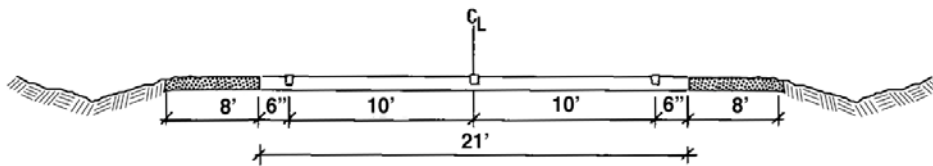

Roadway Retrofitted with 4-Ft Paved Shoulders

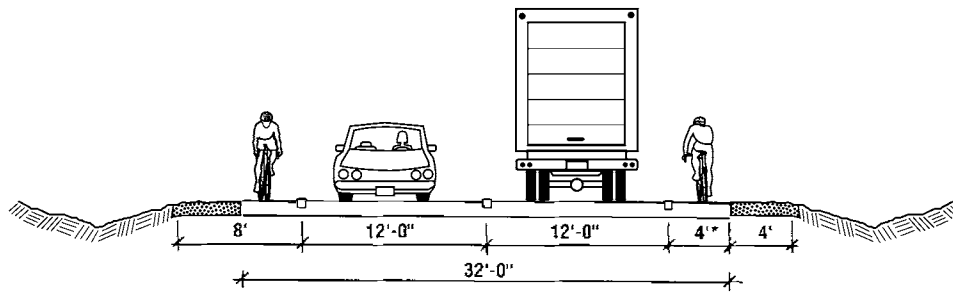

* If speeds are higher than 40 mph, shoulder widths greater than 4' are recommended.

Typical Bicycle Cross Sections

B-5 RECOMMENDED TYPICAL SECTION OF 10-FT ASPHALT PATHWAY With 2-Ft Select Material Shoulder

