

TYPE "E" SIGNS

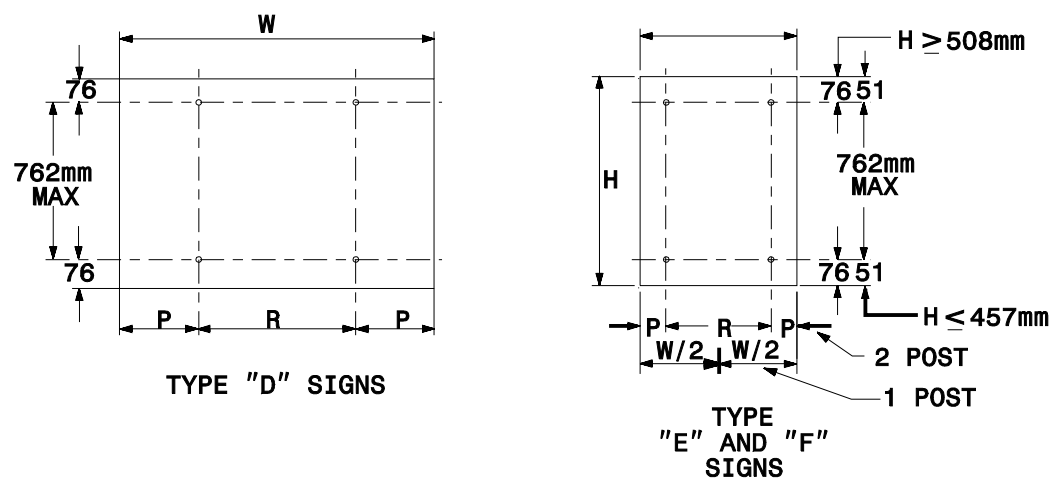

TYPE "D" SIGNS

TYPE "E" AND "F" SIGNS

	NO. SUPPORTS		
	2	3*	4
P	0.207W	0.145W	0.107W
R	0.586W	0.355W	0.262W

UNITS ON ATTACHED SHEET
*MINIMUM 1.07m BETWEEN CHANNEL POSTS

HOLE PUNCHING DETAIL

300mm DIA. ROUND OR SQUARE SMOOTH WALL
HOLE DRILLED, CORED, FORMED
OR AIR HAMMERED AND BACKFILLED
WITH SOIL.

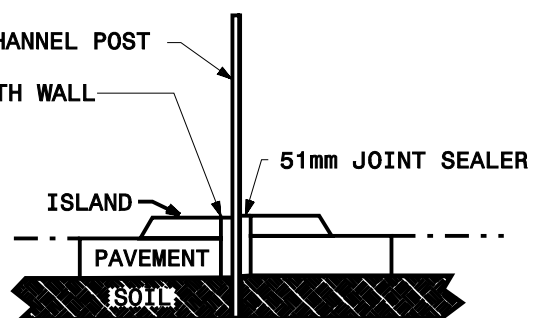

DETAIL FOR INSTALLATION OF
CHANNEL POST IN CONCRETE

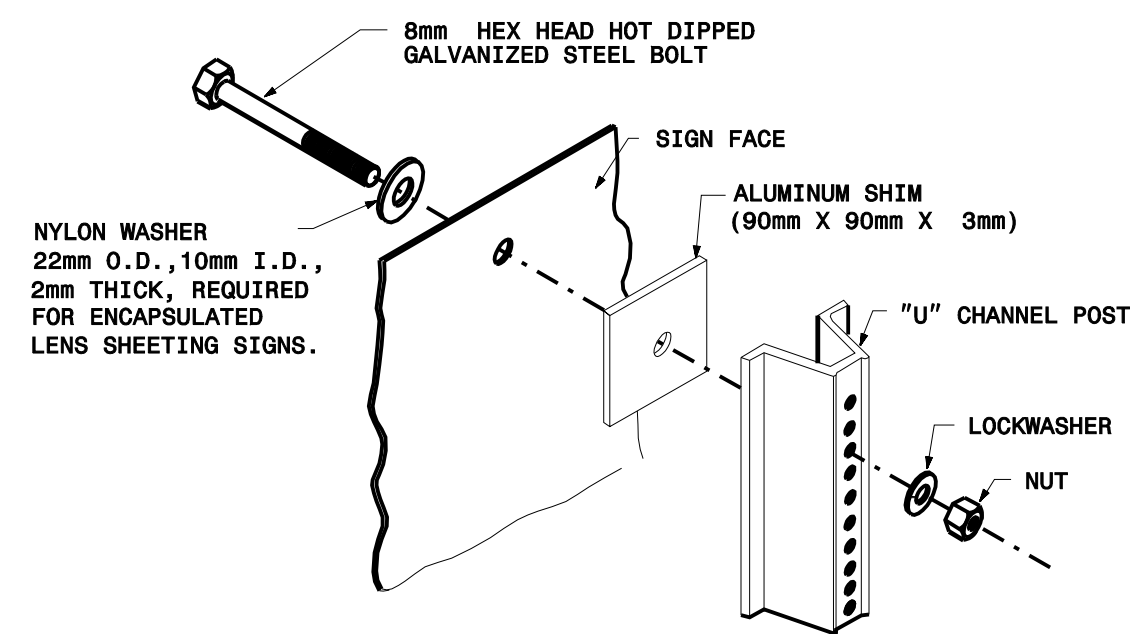

ASSEMBLY DETAIL

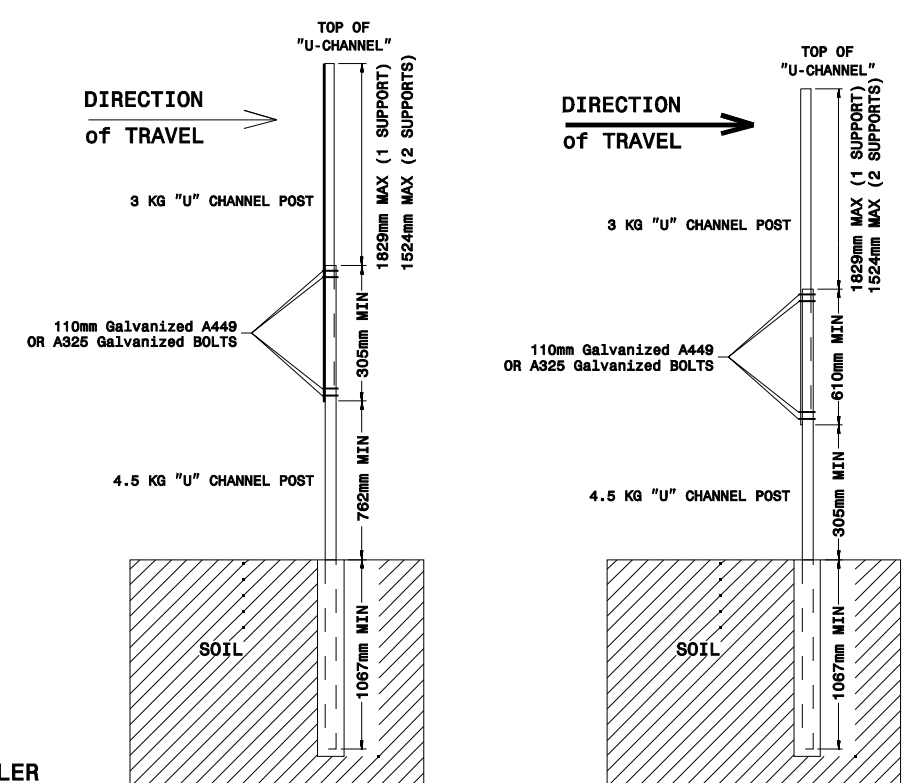

TO BE USED WITH A SIGN AREA OF 0.83 M² OR LESS ON SINGLE POST
TO BE USED WITH A SIGN AREA OF 2.23 M² OR LESS ON TWO POSTS

DETAILS FOR SPLICING
STEEL U-CHANNEL POST
ON SMALL SIGN SUPPORT*

*MAINTENANCE ONLY

Note:
This drawing is dimensioned in millimeters unless otherwise depicted within the drawing.